

VIBRATION MANAGEMENT CORPORATION

3532-A EAST TC JESTER , BROOKWOOD BUSINESS PARK , HOUSTON , TEXAS 77018 , U.S.A

INTERNET ADDRESS: www.vimco.biz

SPECIFICATION

Mounting	Center Back Connection Direct Mounting Bottom Connection Direct Mounting		
Pointer	Micrometer Zero Adjustment Pointer		
Accuracy	1% of F.S.D.		
Range	-20°F (-30°C)	to	120°F (50°C)
	-20°F (-30°C)	to	160°F (70°C)
	30°F (0°C)	to	130°F (55°C)
	30°F (0°C)	to	200°F (100°C)
	30°F (0°C)	to	240°F (120°C)
	30°F (0°C)	to	300°F (150°C)
	30°F (0°C)	to	400°F (200°C)
	30°F (0°C)	to	480°F (250°C)

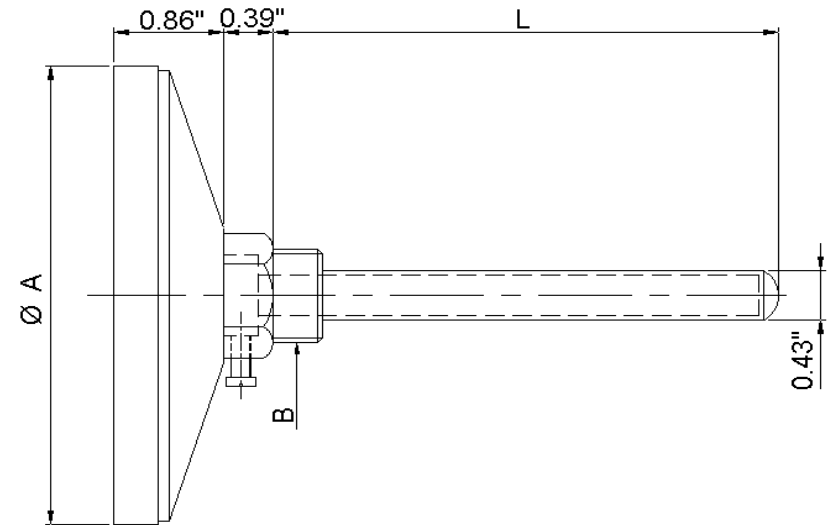

* All dimensions are in inches unless otherwise indicated

DIMENSIONS

Nominal Size (Ø A)	2 1/2", 3", 4"
Immersion Length (L)	2 1/2", 3", 4", 6"
Process Connection (B)	1/2" male (NPT / BSP)

How to Order:

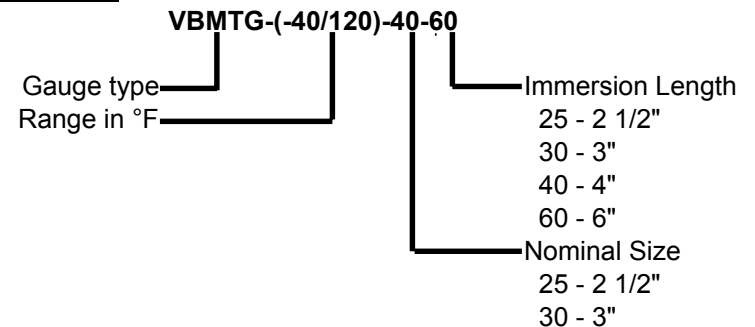

* Specify mounting style + optional construction (if required) when ordering.

MATERIAL OF CONSTRUCTION

Sensing Element	Bi-Metal Helical Coil
Case	Stainless Steel Brass Chrome-Plated Brass Stove Enameled Black Coated
Bezel	Stainless Steel Brass Chrome-Plated Brass Stove Enameled Black Coated
Window	Acrylic Shatter Proof Glass
Stem	Brass (Natural Finish) Brass Chrome-Plated
Pocket	Brass (Natural Finish) Brass Chrome-Plated Stainless Steel 304 / 316

NOTES:

- Data in bold is standard construction.

Notes / Remarks :

Project :
Client :
Consultant :
Representative :

Title :

**Bi-Metal
Temperature Gauges**

Drawing no.
S-2720.21

Rev. 1