

VIBRATION MANAGEMENT CORPORATION

3532-A EAST TC JESTER , BROOKWOOD BUSINESS PARK , HOUSTON , TEXAS 77018 , U.S.A

INTERNET ADDRESS: www.vimco.biz

MODEL	PIPE SIZE (inches)	PART DIMENSIONS (inches)						MAX. LOAD (lbs)
		A	B	C	D	E	F	
ALRSG-40-P/G	4	5/8	18	6 3/4	4 3/4	2 3/4	3/4	750
ALRSG-50-P/G	5	5/8	18	8 1/16	5 13/16	3 3/8	3/4	750
ALRSG-60-P/G	6	3/4	24	9 9/16	6 7/8	3 15/16	1 1/8	1070
ALRSG-80-P/G	8	7/8	24	11 15/16	8 7/8	5 1/16	1 1/8	1350
ALRSG-100-P/G	10	7/8	30	14 1/16	11	6 1/4	1 1/8	1730
ALRSG-120-P/G	12	7/8	30	15 13/16	13	7 3/8	1 1/8	2400
ALRSG-140-P/G	14	1	36	17 3/4	14 1/4	8 1/4	1 1/2	3130

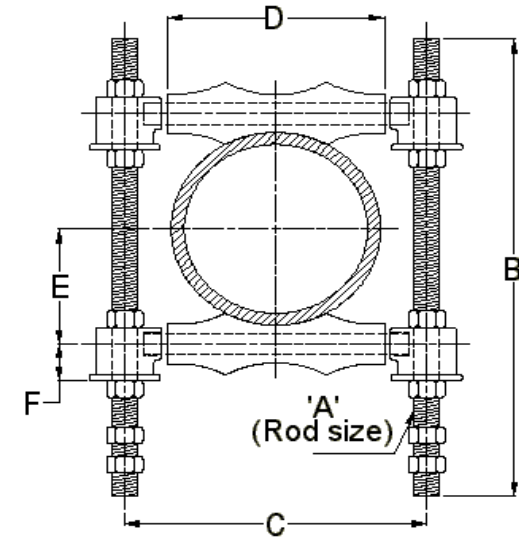

NOTES

- Choose appropriate model for required finish:
P - Plain , G - Electroplated
- Refer protection shield catalogs for sizing information for insulated pipes.

APPLICATION

- * Support and guide of insulated / non-insulated pipes where longitudinal movement, due to expansion and contraction, may occur, and vertical adjustment is required.

MATERIALS

Item	Description
Roller	Cast Iron
Axle + Rods + Hex Nuts	Low carbon steel
Sockets	Malleable Cast Iron

FEATURES

- * Design allows for vertical adjustment of pipe after installation.

Notes / Remarks :

Project :
Client :
Consultant :
Representative :

Title :

ALRSG
Adjustable Long
Roller Support + Guide

Drawing no.
S-2733.04

Rev. 1